



**Quantum**  
SERIES EXCAVATORS®

**3900**

SPECIFICATIONS

62,900 lbs. (28 526 kg) Operating Weight

**Link-Belt**  
EXCAVATORS  
SCRAPMASTER | LOGMASTER

# 3900 Quantum Specifications

## ENGINE

Cummins 6CT8.3 turbocharged, water cooled, 4-cycle diesel, 6 cylinder, 506 CID (8 300 cc), 4.49" (114 mm) bore x 5.31" (135 mm) stroke.

SAE net horsepower ..... 178 HP (133 kW) @ 2,200 rpm  
Maximum torque ..... 516 ft.-lbs. (71.4 kg-m or 700 N-m) @ 1,450 rpm  
Starter ..... Electric, 24V, 7 kW  
Alternator ..... 65 amp  
Air cleaner ..... Double element  
Governor ..... Variable speed, mechanical

## HYDRAULIC SYSTEM

Two variable displacement axial piston pumps and one gear pump for pilot controls, with Link-Belt Intelligent Quantum (IQ) Control. Link-Belt IQ Control includes: four selectable working modes, presettable allied attachment work mode, free swing, one-touch decelerator, auto idling system, power up mode, selectable cushion attachment control, and three safety lockout switches including gate lock.

### Hydraulic Pumps

Two variable volume piston pumps provide power for attachment, swing and travel.

Maximum flow ..... 2 x 56 gpm (2 x 212 l/min)  
Pilot pump max. flow ..... 5.8 gpm (22 l/min)

### Relief Valve Settings

Boom (up)/arm/bucket ..... 4,550 psi (320 kg/cm<sup>2</sup>)  
in Power Up Mode ..... 4,980 psi (350 kg/cm<sup>2</sup>)  
Boom (down) ..... 3,555 psi (250 kg/cm<sup>2</sup>)  
Swing circuit ..... 4,050 psi (285 kg/cm<sup>2</sup>)  
Travel circuit ..... 4,980 psi (350 kg/cm<sup>2</sup>)

**Hydraulic Cylinders** – number of cylinders – bore x rod x stroke.

Boom ..... 2 – 5.1" x 3.5" x 50.3" (130 mm x 90 mm x 1 278 mm)  
Arm ..... 1 – 6.3" x 4.3" x 64.1" (160 mm x 110 mm x 1 627 mm)  
Bucket ..... 1 – 5.3" x 3.5" x 42.2" (135 mm x 90 mm x 1 073 mm)

### Oil Filtration

Nephron filter ..... 1 micron  
Return, pilot, drain filter ..... 10 micron  
Suction filter ..... 105 micron

**Control Valve** One 4-spool valve and one 5-spool valve with auxiliary spool.

## CAB AND CONTROLS

Cab mounted on 6 fluid filled mountings. Features include a safety glass front window and LEXAN® MARGARD™ rear and side windows, reclining/sliding cloth upholstered suspension seat with headrest and armrests, heater, oscillating fan, AM/FM radio, cigarette lighter, pop-up skylight window, and intermittent wiper with washer. Front window slides upward for storage and the lower front window is removable. Control levers are located in 4-position tilting control consoles. Reliable soft-touch switches. Easy-to-read illuminated LCD service monitor keeps operator in touch with critical machine functions.

## SWING

Planetary reduction powered by axial piston motor. Internal ring gear with grease cavity for swing pinion. Swing bearing is single-row shear type ball bearing. Swing cushion valve and dual stage relief valves for smooth swing deceleration and stops. Mechanical disc swing brake.

Swing speed ..... 0 – 10.4 rpm  
Tail swing ..... 9' 10" (3.00 m)  
Swing torque ..... 55,150 ft.-lbs. (7 625 kg-m)

## UNDERCARRIAGE

X-style carbody is integrally welded for strength and durability. Grease cylinder track adjusters with shock absorbing springs. LC undercarriage with sealed track, lubricated rollers and idlers. Triple grouser track shoes.

Carrier rollers ..... 2 per side  
Track rollers ..... 9 per side  
Shoes ..... 50 per side  
Shoe width ..... 31.5" (800 mm)  
Ground pressure ..... 5.97 psi (.42 kg/cm<sup>2</sup>)

Alternating inner and outer flanged rollers are used to assure proper track rail to roller engagement.

## TRAVEL SYSTEM

Three-speed independent hydrostatic travel with compact axial piston motors for increased performance. Hydraulic motor powered output shaft coupled to a planetary reduction unit and track sprocket. All hydraulic components mounted within the width of side frame. Travel speeds selected by floor mounted foot switch.

**Automatic Downshift:** When operating in difficult travel conditions or on slopes, travel motor automatically downshifts from high speed to mid-range speed for increased tractive effort. Machine will automatically return to high speed after traveling out of difficult terrain.

**Single Pedal Travel:** Engage both tracks simultaneously.

Max. travel speed ..... 1.3/1.9/3.0 mph (2.1/3.1/4.8 km/h)  
Traction force ..... 47,417 lbs. (21 508 kg)  
Gradeability ..... 70%

Spring applied, hydraulically released disc parking brake built into each motor. Each travel motor equipped with counterbalance valve to prevent over-speeding down an incline and dual stage reliefs for smooth starts and stops.

## LUBRICANT & COOLANT CAPACITY

Hydraulic tank ..... 32 gal. (120 liters)  
Hydraulic system ..... 58 gal. (220 liters)  
Final drive (per side) ..... 1.2 gal. (4.7 liters)  
Swing drive ..... 1.6 gal. (6.0 liters)  
Engine ..... 5.0 gal. (19.0 liters)  
Fuel tank ..... 82 gal. (310 liters)  
Cooling system ..... 6.8 gal. (25.8 liters)

## ATTACHMENT

### Available Arms

• 11' 2" (3.40 m) ..... 25,932 lbs. (11 760 kg)  
in Power Up Mode – 28,363 lbs. (12 863 kg)  
• 13' 0" (4.00 m) ..... 23,795 lbs. (10 791 kg)  
in Power Up Mode – 26,026 lbs. (11 805 kg)  
Bucket digging force ..... 31,109 lbs. (14 108 kg)  
in Power Up Mode – 34,026 lbs. (15 431 kg)

### Digging Force

## OPERATING WEIGHT

Working weight with 31.5" (800 mm) shoes, 11' 2" (3.40 m) arm and 1,830 lb. (830 kg) bucket ..... 62,900 lbs. (28 526 kg)

## STANDARD EQUIPMENT

- Cummins 6CT8.3 diesel engine
- 65 amp alternator
- Double element air filter
- 24-volt starting system, battery lighting system, sealed heavy duty electrical connectors
- Ether Starting Aid
- Intelligent Quantum (IQ) Control with manual backup system
- Self-diagnostic system
- Nephron filtration system
- Swing-out oil cooler
- Four selectable working modes
- One-touch decelerator
- Auto idling system
- Auto engine warm up
- Power up mode
- Integral cylinder cushioning
- Cushion attachment control
- Boom and arm holding valves
- Free swing control
- 3-speed hydrostatic travel
- Single pedal travel
- Travel alarm
- Spare accessory valve
- Sliding/reclining, suspension cloth upholstered seat with 4-position tilting consoles and sliding platform
- Illuminated LCD service monitor
- Heater, fan, seat belt, horn, dome light, AM/FM radio, digital clock, floor mat, cigarette lighter
- Safety glass front window with automatic lock and intermittent windshield wiper and washer, large LEXAN® rear/side windows
- Vandalism locks/guarding
- Hand grab rails both sides
- Upper and lower undercovers
- LC undercarriage
- 12,390 lbs. (5 620 kg) counterweight
- Quick disconnects in hydraulic system for easy pressure checking

## DIMENSIONS

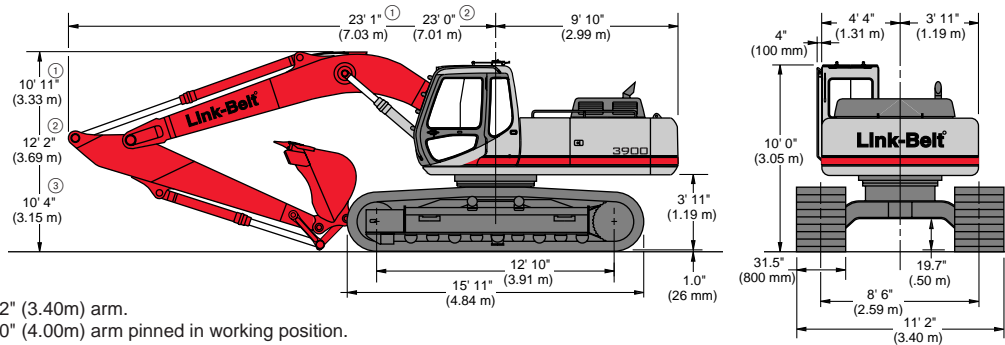

- ① Machine equipped with 11' 2" (3.40m) arm.
- ② Machine equipped with 13' 0" (4.00m) arm pinned in working position.
- ③ Machine equipped with 13' 0" (4.00m) arm pinned in transport position.

## WORKING RANGES

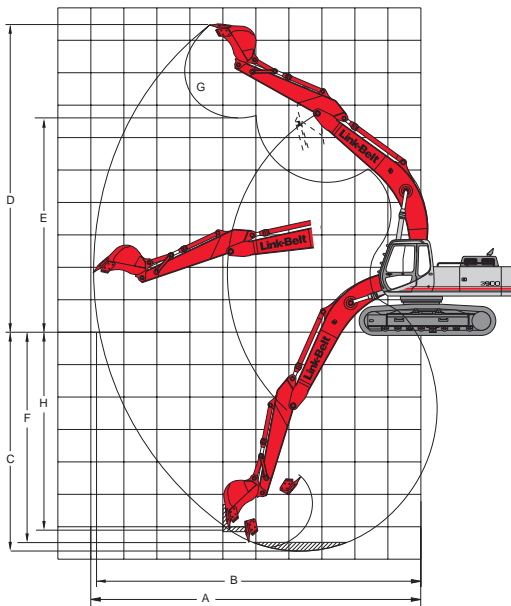

	19' 2" (5.85 m) Boom	
	11' 2" Arm 3.40 m	13' 0" Arm 4.00 m
<b>A</b> Max. digging radius	35' 4" 10.77 m	36' 10" 11.24 m
<b>B</b> Max. digging radius @ ground level	34' 9" 10.59 m	36' 4" 11.07 m
<b>C</b> Max. digging depth	23' 7" 7.19 m	25' 5" 7.75 m
<b>D</b> Max. digging height	33' 3" 10.15 m	33' 6" 10.23 m
<b>E</b> Max. dumping height	23' 2" 7.07 m	23' 6" 7.18 m
<b>F</b> Digging depth – 8' (2.44 m) level bottom	23' 1" 7.04 m	24' 11" 7.61 m
<b>G</b> Bucket wrist angle	180°	180°
<b>H</b> Max. vertical wall depth	21' 0" 6.41 m	22' 11" 7.00 m

## BUCKETS

Bucket Type	Capacity	Width Outside Lip	Weight	# Teeth	Arms	
					11' 2" (3.40 m)	13' 0" (4.00 m)
ESCO STDP	.75 cu. yd. (.57 m <sup>3</sup> )	24" (610 mm)	1,528 lb. (693 kg)	4	H	H
	1.0 cu. yd. (.76 m <sup>3</sup> )	30" (762 mm)	1,690 lb. (767 kg)	4	H	H
	1.25 cu. yd. (.96 m <sup>3</sup> )	36" (914 mm)	1,851 lb. (840 kg)	5	H	H
	1.5 cu. yd. (1.15 m <sup>3</sup> )	42" (1 067 mm)	2,017 lb. (915 kg)	5	M	M
	1.75 cu. yd. (1.34 m <sup>3</sup> )	48" (1 219 mm)	2,139 lb. (970 kg)	5	M	L
	2.0 cu. yd. (1.53 m <sup>3</sup> )	54" (1 372 mm)	2,332 lb. (1 057 kg)	6	L	L
ESCO HDP	.75 cu. yd. (.57 m <sup>3</sup> )	24" (610 mm)	1,838 lb. (834 kg)	3	H	H
	1.0 cu. yd. (.76 m <sup>3</sup> )	30" (762 mm)	2,081 lb. (944 kg)	4	H	H
	1.25 cu. yd. (.96 m <sup>3</sup> )	36" (914 mm)	2,273 lb. (1 031 kg)	4	H	H
	1.5 cu. yd. (1.15 m <sup>3</sup> )	42" (1 067 mm)	2,517 lb. (1 142 kg)	5	M	M
	1.75 cu. yd. (1.34 m <sup>3</sup> )	48" (1 219 mm)	2,764 lb. (1 254 kg)	5	L	L
	2.0 cu. yd. (1.53 m <sup>3</sup> )	54" (1 372 mm)	2,965 lb. (1 345 kg)	6	L	N/A
ESCO XDP	.88 cu. yd. (.67 m <sup>3</sup> )	30" (762 mm)	3,092 lb. (1 403 kg)	4	H	H
	1.12 cu. yd. (.86 m <sup>3</sup> )	36" (914 mm)	3,326 lb. (1 509 kg)	4	H	M
	1.38 cu. yd. (1.06 m <sup>3</sup> )	42" (1 067 mm)	3,712 lb. (1 684 kg)	5	M	L
	1.62 cu. yd. (1.24 m <sup>3</sup> )	48" (1 219 mm)	3,946 lb. (1 790 kg)	5	L	N/A
ESCO HDC	.875 cu. yd. (.67 m <sup>3</sup> )	30" (762 mm)	2,085 lb. (946 kg)	4	H	H
	1.0 cu. yd. (.76 m <sup>3</sup> )	33" (838 mm)	2,204 lb. (1 000 kg)	4	H	H
	1.25 cu. yd. (.96 m <sup>3</sup> )	39" (991 mm)	2,342 lb. (1 062 kg)	4	H	M
	1.50 cu. yd. (1.15 m <sup>3</sup> )	45" (1 143 mm)	2,724 lb. (1 235 kg)	5	M	L
	1.88 cu. yd. (1.44 m <sup>3</sup> )	55" (1 397 mm)	3,335 lb. (1 512 kg)	5	L	N/A

### Approval Code For Arm/Bucket Combinations

H ..... Heavy material  
(up to 3,370 lbs./cu. yd.)

M ..... Medium material  
(up to 2,700 lbs./cu. yd.)

L ..... Light material  
(up to 2,020 lbs./cu. yd.)

N/A ... Not applicable

# 3900 Quantum Lifting Capacities

## 11' 2" (3.40 m) ARM EQUIPPED WITH 1,830 LB. (830 KG) BUCKET POWER UP MODE APPLIED

Bucket Hook Height		Radius of Load											
		10' 0" (3.05 m)		15' 0" (4.57 m)		20' 0" (6.10 m)		25' 0" (7.62 m)		30' 0" (9.14 m)		Capacity at Max. Reach	
		End	Side	End	Side	End	Side	End	Side	End	Side	End	Side
+20' 0" (6.10 m)	lbs. kg							9,600* 4 354*	9,600* 4 354*			6,150* 2 789*	6,150* 2 789*
+15' 0" (4.57 m)	lbs. kg							10,150* 4 604*	10,150* 4 604*	9,050* 4 105*	7,600 3 447	6,050* 2 744*	6,050* 2 744*
+10' 0" (3.05 m)	lbs. kg	10,500* 4 763*	10,500* 4 763*	16,050* 7 280*	16,050* 7 280*	13,000* 5 897*	13,000* 5 897*	11,150* 5 057*	10,400 4 717	10,000* 4 536*	7,450 3 379	6,200* 2 812*	5,850 2 653
+5' 0" (1.52 m)	lbs. kg	31,200* 14 152*	31,200* 14 152*	21,150* 9 593*	21,150* 9 593*	14,900* 6 758*	14,100 6 395	12,250* 5 556*	9,900 4 490	10,500* 4 762*	7,250 3 288	6,550* 2 971*	5,750 2 608
Ground	lbs. kg	24,450* 11 090*	24,450* 11 090*	24,300* 11 022*	20,700 9 389	16,900* 7 665*	13,350 6 055	13,150* 5 964*	9,450 4 286	10,850* 4 921*	7,000 3 175	7,100* 3 220*	5,950 2 698
-5' 0" (1.52 m)	lbs. kg	28,550* 12 950*	28,550* 12 950*	24,850* 11 271*	20,100 9 117	17,800* 8 074*	12,900 5 851	13,650* 6 191*	9,150 4 150	10,800* 4 898*	6,900 3 129	8,100* 3 674*	6,600 2 993
-10' 0" (3.05 m)	lbs. kg	36,500* 16 556*	36,500* 16 556*	24,150* 10 954*	20,150 9 140	17,500* 7 938*	12,800 5 806	13,250* 6 010*	9,100 4 127	9,100 4 127	9,100 4 127	9,700* 4 399*	7,900 3 583
-15' 0" (4.57 m)	lbs. kg	31,750* 14 401*	31,750* 14 401*	21,650* 9 820*	20,450 9 276	15,650* 7 098*	13,000 5 896	10,550* 4 785*	9,450 4 286			8,750* 3 969*	8,750* 3 969*
-20' 0" (6.10 m)	lbs. kg	22,800* 10 342*	22,800* 10 342*	15,650* 7 098*	15,650* 7 098*								

## 13' 0" (4.00 m) ARM EQUIPPED WITH 1,510 LB. (685 KG) BUCKET POWER UP MODE APPLIED

+20' 0" (6.10 m)	lbs. kg							8,600* 3 900*	8,600* 3 900*			5,850* 2 653*	5,850* 2 653*
+15' 0" (4.57 m)	lbs. kg							9,300* 4 218*	9,300* 4 218*	8,850* 4 014*	7,850 3 560	5,800* 2 630*	5,800* 2 630*
+10' 0" (3.05 m)	lbs. kg					11,900* 5 397*	11,900* 5 397*	10,400* 4 717*	10,200 4 626	9,550* 4 331*	7,650 3 470	5,950* 2 698*	5,500 2 494
+5' 0" (1.52 m)	lbs. kg	29,400* 13 335*	29,400* 13 335*	19,200* 8 709*	19,200* 8 709*	14,200* 6 441*	13,950 6 327	11,650* 5 284*	10,050 4 558	10,150* 4 604*	7,350 3 333	6,300* 2 857*	5,350 2 426
Ground	lbs. kg	28,350* 12 859*	28,350* 12 859*	23,250* 10 546*	21,000 9 525	16,200* 7 348*	13,500 6 123	12,750* 5 783*	9,550 4 331	10,650* 4 830*	7,100 3 220	6,850* 3 107*	5,550 2 517
-5' 0" (1.52 m)	lbs. kg	29,000* 13 154*	29,000* 13 154*	24,750* 11 226*	20,100 9 117	17,500* 7 938*	12,950 5 874	13,450* 6 100*	9,200 4 173	10,850* 4 921*	6,900 3 129	7,800* 3 538*	6,000 2 721
-10' 0" (3.05 m)	lbs. kg	36,750* 16 669*	36,750* 16 669*	24,450* 11 090*	19,950 9 049	17,650* 8 006	12,750 5 783	13,450* 6 100*	9,050 4 105	10,300* 4 672*	6,900 3 129	9,350* 4 241*	7,050 3 197
-15' 0" (4.57 m)	lbs. kg	34,000* 15 422*	34,000* 15 422*	22,750* 10 319*	20,200 9 162	16,500* 7 484*	12,850 5 828	12,150* 5 511*	9,200 4 173			9,150* 4 150*	9,150* 4 150*
-20' 0" (6.10 m)	lbs. kg	26,850* 12 179*	26,850* 12 179*	18,350* 8 323*	18,350* 8 323*	12,700* 5 760*	12,700* 5 760*						

### Notes: Excavator lifting capacities

- Lifting capacities shown should not be exceeded. Weight of all lifting accessories must be deducted from the above lifting capacities.
- Lifting capacities are based on machine standing on firm, uniform supporting surface. User must make allowances for job conditions such as soft or uneven ground.
- Lifting capacities shown do not exceed 75% of minimum tipping loads or 87% of hydraulic capacities. Capacities marked with an asterisk (\*) are limited by hydraulic capacities.
- These capacities apply to machines having 4,980 psi (350 kg/cm<sup>2</sup>) boomhoist cylinder pressure.
- Least stable position is over the side.
- Lifting capacities are in compliance with SAE J1097 and ISO 10567. Operator should be fully acquainted with the Operator's Manual & Operating Safety Booklet, furnished by manufacturer before operating the machine.
- Capacities apply only to the machine as originally manufactured and normally equipped by LBX Company, LLC.

# Quantum

SERIES EXCAVATORS

## Intelligent Quantum (IQ) Control "The Smart System"

- **Four selectable working modes.** The mode selection system enables the operator to program the machine's speed to the job application:  
H: Heavy Mode ..... For heavy digging jobs, or any time you need extra power  
S: Standard Mode ..... For standard digging and loading operations  
L: Light Mode ..... For grading and other jobs where safety and precision are more important than power  
F: Fine Mode ..... For lifting and operations that need fingertip accuracy
- **Presettable allied attachment work mode**
- **Selectable cushion attachment control**
- **Self-Diagnostic System**
- **Auto engine warm up**

**Hose Burst Check Valves (HBCV)** Optional

**Integral Cylinder Cushion Design**

- **Attachment**  
New design heavy duty box section attachment with central lube bank.

- **Illuminated LCD Service Monitor**  
Programmable in 14 languages.

- **Operator's Control Station**  
Mounted on 6 fluid mountings with: heater, oscillating fan, seat belt, horn, dome light, AM/FM radio, digital clock, and 3 safety control lockouts including a gate lock safety shutoff.

- **Buckets**  
Wide variety of quality Escobuckets with Super V tooth system.

- **Power Up Button**  
9% power increase at the touch of a button.

- **One-Touch Decelerator or Auto Idling**  
Operator has choice of one-touch decelerator or programmable auto idling.

- **Hand Grab Rails**  
Standard on operator's cab and on top of both sides of machinery house.

- **Boom Holding Valves**

- **Nephron Oil Filtration System**  
Cleans the hydraulic fluid of condensation and all contaminants over one micron in diameter.

- **Diesel Engines**  
Turbocharged, reliable, fuel efficient, and quiet.

- **Swing-Out Oil Cooler**  
Opens 60° for easy maintenance.  
(Standard on 2800, 3400, 3900 & 4300)

- **Long Undercarriage**  
LC undercarriage with heavy duty excavator style components.

- **Auxiliary Spool**  
For allied attachments.

- **Track Frame**  
Reduces soil buildup.

- **Alternating Inner/Outer Flanged Rollers**  
Assures proper rail engagement; filled with synthetic oil.

- **Operator's Seat**  
Reclining/sliding fully suspended seat for all day comfort.

- **Control Console**  
4-position tilting/sliding.

- **Undercovers**  
Fully covered upper and lower.

- **Superior Visibility**

Safety glass front window. LEXAN® MARGARD™ rear and side windows eliminate need for vandal covers.

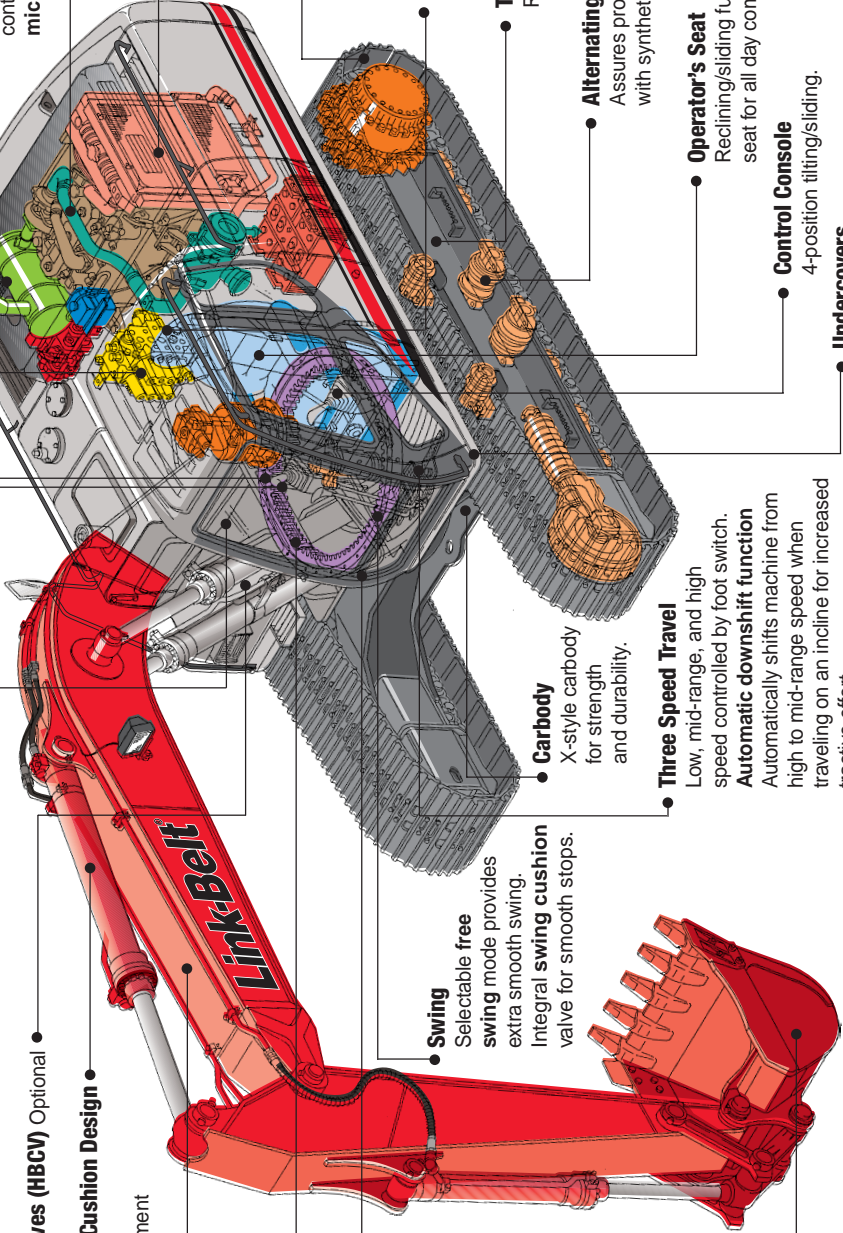

- **Swing**

Selectable free swing mode provides extra smooth swing. Integral swing cushion valve for smooth stops.

- **Three Speed Travel**

Low, mid-range, and high speed controlled by foot switch. **Automatic downshift function** Automatically shifts machine from high to mid-range speed when traveling on an incline for increased tractive effort.

**Single pedal travel** Standard on 3400, 3900, 4300 and 5800.

- **Carbody**

X-style carbody for strength and durability.

# Quantum Added Value Features



**Operator's Control Station** Offers superior visibility and more! The operator's control station is designed with the operator in mind, and is mounted to the frame on six fluid filled mountings for minimal vibration. Features include a wide opening door, a cloth upholstered suspension seat with integral headrest and armrests, heater with 3-speed fan, AM/FM radio, cigarette lighter, pop-up skylight window, oscillating fan, and intermittent windshield wiper with washer.

## Nephron Oil Filtration System

The Nephron filter eliminates contaminants of 1 micron or more in size. This significantly reduces hydraulic system breakdown and maintenance costs under normal usage. Less wear and tear on the hydraulic components means you get more years of reliable performance from your Quantum.



**Long Carriage Undercarriage** Long undercarriages incorporate heavy duty excavator style components. X-style carbody is integrally welded for maximum strength and durability. Newly designed side frames incorporate a peaked saddle shape and large cut-outs on top for reduced dirt build-up. Track adjustment is



made easy with standard grease cylinder track adjusters and shock absorbing springs.

**Bearing "Tub"** Built into the "X" style carbody is the turntable bearing "tub" which extends down through the top plate and is welded to the bottom of the carbody as well as the top for increased strength.

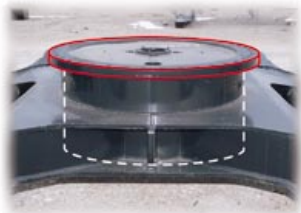

## Swing Out Oil Cooler

A swing out oil cooler assembly is standard on the 2800, 3400, 3900 and 4300. Compared to competition, this unit provides exceptional wide opening access (60°) for easy, thorough cleaning. A removable dust protection screen situated in front of the oil cooler protects the cores from large particles of dust.



**Serviceability** Servicing the Quantum excavator is simplified by the use of large, wide opening doors. Standard quick disconnects for pressure checking and central lube banks for attachment pins also provide quick routine maintenance. A grease gun and tool kit are provided as standard service equipment.



**Product Support** With Link-Belt, your excavation investment is always protected. With a coast-to-coast distributor network, you're never far from Link-Belt.

**Illuminated LCD Service Monitor** Easy to read illuminated monitor can display up to 19 messages including work modes, power up, free swing, engine idling, auto warm up, engine preheat ... and several other audio



visual caution and warning messages which keep the operator in touch with critical machine functions. A bar graph display section constantly monitors the water temperature, hydraulic oil temperature and fuel level. Also continuously displayed on the monitor are selected travel speed, swing lock on/off, working mode and a digital clock.

**Free Swing Control** The standard free swing feature allows the operator to disengage the swing brake providing precise control and smooth stops when swinging a load. The swing brake can be engaged to eliminate the upper from coasting when working on a hillside.



## Cushioned Attachment Control

Push-button cushioned attachment control can be selected for the boom and arm hydraulic circuits which incorporate a cushion valve to further reduce shock and vibration.



**Power Up Mode** A button on the right controller lets the operator apply more power instantly. A touch of the button gives the system a 9% power boost for 8 seconds...ideal for powering through those tough rocks and stumps or lifting a heavier load.

**One Touch Decelerator** The operator can also control engine idling by using the one-touch decelerator located on top of the right control lever. The operator can push this button to bring the engine speed down to idle while waiting for trucks, etc. Another touch of the button brings the engine rpm back to the original throttle setting.